

Inspection Hatch

rectangular cover plate

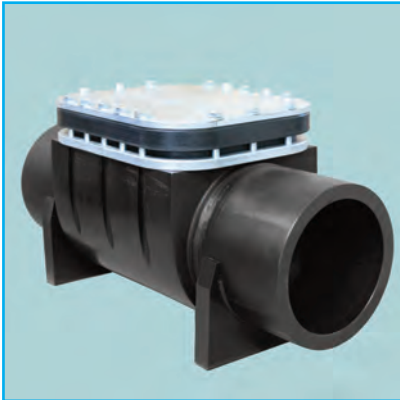

Up to 4 bar (Version 1)
Optional with stand

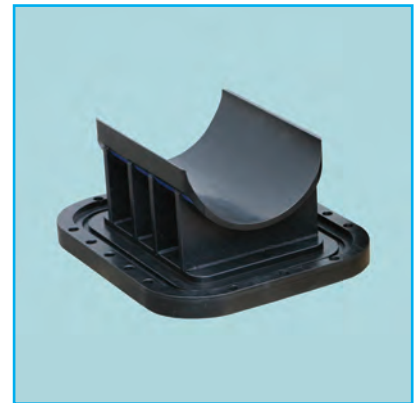

Cover for scraper (pig) trap



Up to 16 bar (Version 2)

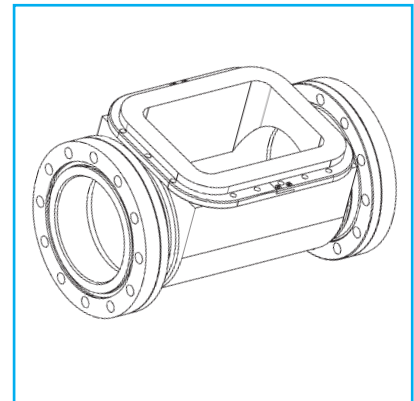

Optional: Both ends with flanged connection solution

- ▶ **PE 100 - SDR 17 / 11**
- ▶ Consisting of: a strengthened, profile body, galvanised bolt set/flange, EPDM O-ring seal
- ▶ From d 250 mm, long spigot for electro fusion coupling
- ▶ Version 1: up to 4 bar
- ▶ Version 2: up to 16 bar, galvanised strengthening ribs, tensioning straps with Elastomer
- ▶ Optional: with **REINOLGRIP** coupler, flanged connections for both sides of the fitting, stand

Advantages:

- ▶ Simple disassembly
- ▶ No corrosion
- ▶ Limited weight
- ▶ Cost savings by being weldable

Tender Specification:

PE 100 profile tee piece, d 250 mm, SDR 17, galvanised bolts and flange, O-ring seal, up to 4 bar, cover for scraper (pig) trap, long spigot for electro fusion coupling
(Prepared by: Reinert-Ritz GmbH, Tel.: +49 5921 8347-0
Fax: -25 or comparable)

REINERT-RITZ



Inspection Hatch up to 4 bar

composed of:
galvanised bolt set/flange, EPDM O-ring
seal and cover for scraper (pig) trap

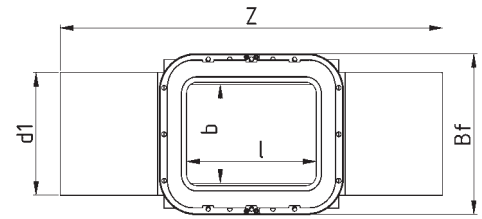
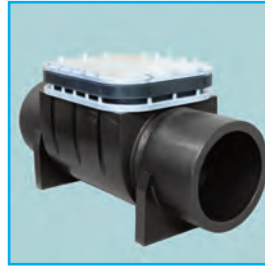

SDR 17/11

d1	b	l	Z	Bf	weight kg	Euro / Piece PE 100
250	200	350	1096	415	89	3380
280	220	350	1096	415	89	3388
315	250	350	1096	415	88	3415
355	280	400	1180	467	170	3812
400	320	498	1270	600	224	6250
450	360	498	1270	600	223	6005
500	400	498	1715	693	359	7174
560	450	498	1715	693	367	7332

Other dimensions upon request



Inspection Hatch up to 16 bar

composed of:
galvanised bolt set/flange, EPDM O-ring
seal and cover for scraper (pig) trap

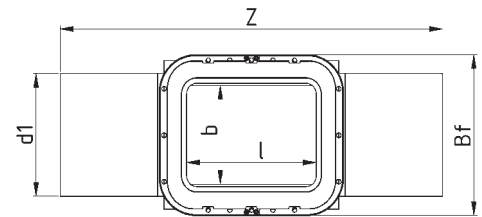

SDR 11

d1	b	l	Z	Bf	weight kg	Euro / Piece PE 100
250	200	350	1096	415	101	3756
280	220	350	1096	415	101	3763
315	250	350	1096	415	100	3791
355	280	400	1180	467	185	4208
400	320	498	1270	600	242	6672
450	360	498	1270	600	241	6425
500	400	498	1715	693	380	7765
560	450	498	1715	693	388	7925

Other dimensions upon request