



VARI-FLANGED COUPLINGS

DN 80 - DN 600

ADAPT A STUB ENDED PIPE OR VALVE TO A FITTING OR PIPE WITH A FLANGED FACE



FEATURES

Manufactured from grade 316 stainless steel and/or fusion bonded epoxy coated ductile iron, depending on size

Non-standard mating flanges are available to cater for customers individual requirements (a standard flange is considered to be to AS 4087 - PN 16)

A specially designed wedge shaped nitrile rubber gasket provides a potable water approved seal at the coupling end

A 24mm OD range at the coupling end enables the product to adapt to most pipe diameters within a nominal size

Fasteners have a captive head design to facilitate easy in-field assembly

Dry film, anti-galling coating employed on stainless steel fasteners to minimise galling

Manufacturing facility certified to the ISO 9001 quality assured standard

DESCRIPTION

Vari-Flanged Couplings are utilised to enable a connection between a stub ended pipe and a mating flanged face.

The use of high quality stainless steel, FBE coated DI and nitrile rubber gaskets permits use of the product in a range of applications from potable water and sewerage to industrial applications

APPLICATION

Vari-Flanged Couplings provide an effective and convenient means of converting a plain ended pipe stub to a flange for connection to another flanged pipe, valve or fitting

A Vari-Flanged Coupling's variable OD range (at the coupling end) enables the product to adapt to most pipes diameters within a nominal size range. This dramatically reduces the stocking requirement to cater for each individual pipe type and size

TECHNICAL DATA

Size Range: DN 80 - DN 600

Maximum Operating Pressure: 1600 kPa (up to and including DN 600).

Temperature Range: -10°C to 60°C

Relevant Standards:
AS/NZS 4998 – Bolted unrestrained mechanical couplings for waterworks purposes

AS 4020 – Potable water approval

VARI-FLANGED COUPLINGS

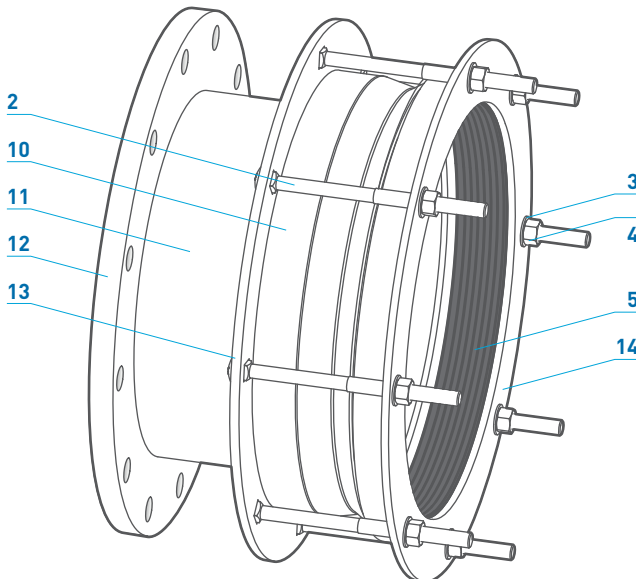
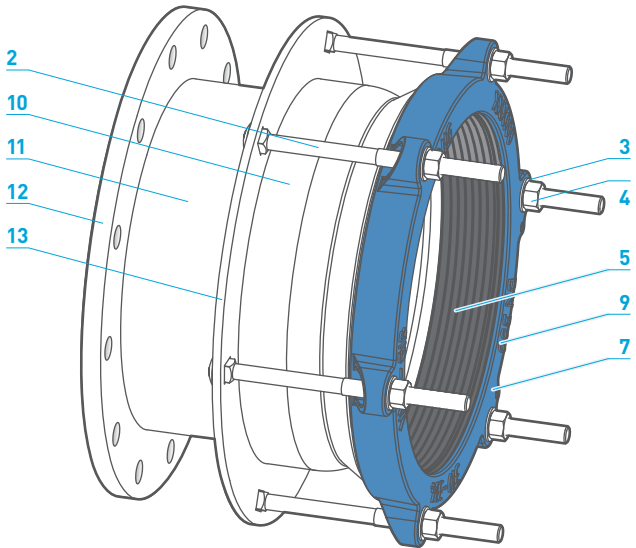
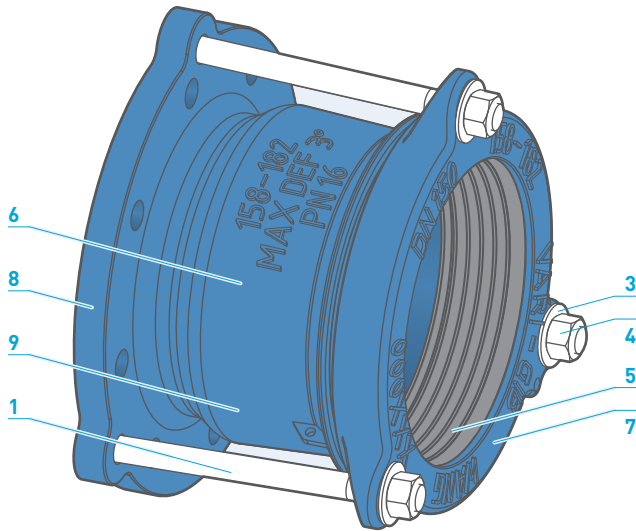

PARTS LIST

No.	Description	Material / Standard
1	Bolts – Hex	316 stainless steel / AS 1110.1
2	Bolts – Carriage	316 stainless steel / DIN 603
3	Washers	316 Stainless Steel / ISO 887 / ISO 7089
4	Nuts	316 stainless steel / AS 1112.1
5	Coupling Gasket	Nitrile (NBR) Compound / AS 1646 & AS/NZS 4020
6	Body (Barrel & Flange)	Ductile Iron / AS 1831
7	Coupling Flange	Ductile Iron / AS 1831
8	Mating Flange	Ductile Iron / AS 1831 Flange Standard to AS/NZS 4087 (compatible with AS2129 Table-D drilling)
9	Coating	Fusion Coated / ASNZS 4158
10	Barrel	316 Stainless Steel / ASTM A240M
11	Pipe	316 Stainless Steel / ASME B36.19M
12	Mating Flange	316 Stainless Steel / ASTM A240M or A182 (Flange Standard: Variable to suit customer needs)
13	Centre Bolting Ring	316 Stainless Steel / ASTM A276
14	Coupling Flange	316 Stainless Steel / ASTM A276

TYPICAL SPECIFYING SEQUENCE

	KV	FA	0109	F	100	D	S	C
KV	= Vari-Gib							
FA	= Flanged Adaptor							
0109	= Start of OD range See adjacent for available OD options							
F	= Flange delineator							
100	= Flange DN size Various flanges available to match coupling from DN 100+							
D	= Material options A = 316 SS barrel with DI fusion coated coupling flanges C = 316 SS barrel and coupling flanges D = DI fusion coated barrel and coupling flanges							
S	= Fastener material – 316 SS							
C	= Flange type C = AS 4087 - PN 16, E = AS 2129 Table E - PN 14, X = DIN flange, Z = ANSI flange							

VARI-FLANGED COUPLINGS

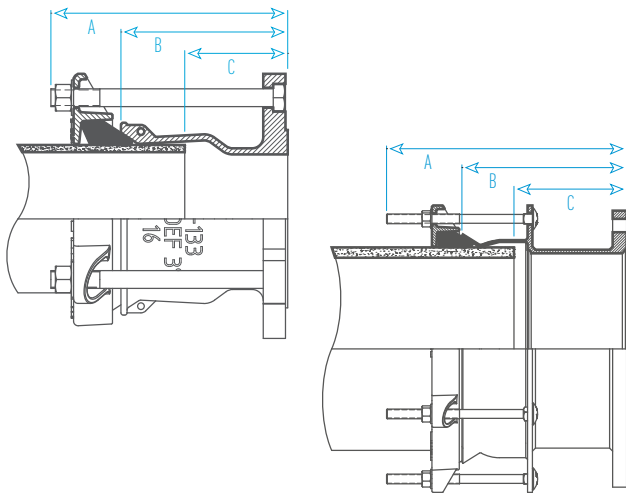

Fusion Coated Ductile Iron Vari-Flanged Coupling

DIMENSIONS

Nominal Size DN	Overall Length A	Barrel Length B	Recommended Pipe Offset C
100	215	150	75
150	215	150	75
200	395	270	180
225	395	270	180
250	395	270	180
300	395	270	180
350 +	Information on request		

All dimensions in millimetres unless stated otherwise
 Note: Dimensions A, B & C are based on PN 16 flat faced flanges to AS 4087
 Other requested flange specifications may alter these stated dimensions

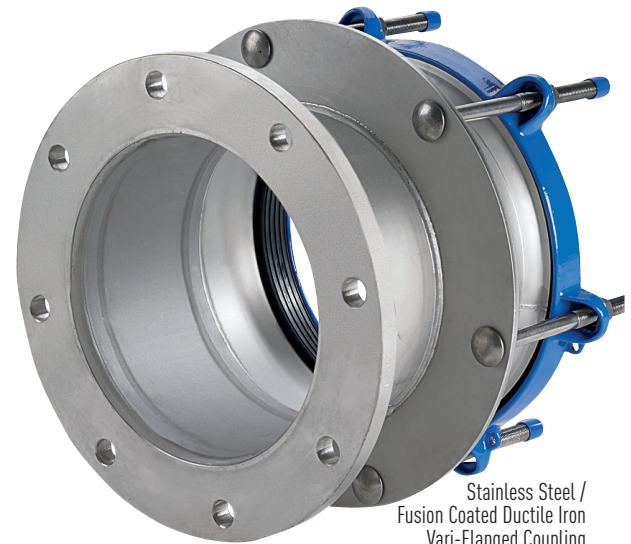

Stainless Steel / Fusion Coated Ductile Iron Vari-Flanged Coupling

COUPLINGS DETAILS

Nominal Size DN	OD range		Bolt		Max. achievable angular pipe deflection
	Start	End	Qty	Size	
100	109	133	3	M16	3°
150	158	182	3	M16	3°
200	214	238	5	M16	3°
225	240	264	5	M16	3°
250	272	296	6	M16	3°
300	310	334	6	M16	3°
	330	354	6	M16	3°
350 +	Information on request				

All dimensions in millimetres unless stated otherwise



Fully Stainless Steel Vari-Flanged Coupling

CLAMPS & COUPLINGS

WANG is one of the leading manufacturers and suppliers of Grade 316 Stainless Steel Repair and Tapped Clamps as well as Couplings for reticulated water, sewerage and gas mains including industrial piping systems.

WANG products have become synonymous with quality and reliability. Our product range is widely utilised and relied upon by Water Authorities and Councils throughout Australia in the installation and maintenance of their supply mains and reticulation network.



WANG products can be sourced through a range of international distributors, their details can be found on our web site.

www.wang.com.au

KWIK CLAMPS

A full circle repair clamp for small bore galvanised steel, copper and PVC pipe. DN 15 - DN 50



HDPE CLAMPS

A range of Flanged, Tapped and Repair Clamps specifically for HDPE pipe installations. DN 40 - DN 600

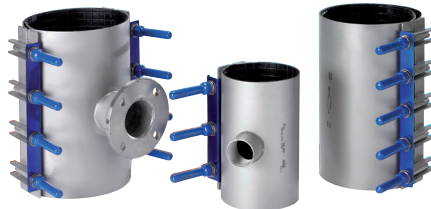

TAPPED CLAMPS

A reliable means of tapping into old, unstable or damaged pipe. DN 50 - DN 1200



TAPPING SADDLES

Permanent tapping solution for both rigid and flexible pipe. DN 40 - DN 450

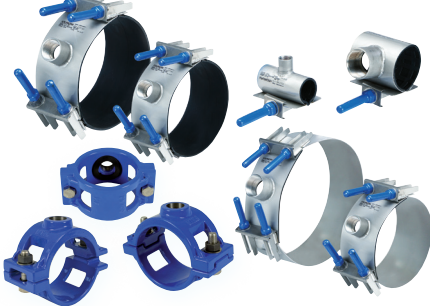

FLANGED OFFTAKE CLAMPS

A cost effective means of achieving a 'T' connection or under pressure tapping. DN 100 - DN 900



SEWER OB JUNCTION CLAMPS

A quick method of installing a new property service connection on a sewer main. DN 100 - DN 450



VARI GIB COUPLINGS

Non-restrained mechanical couplings for connecting pipes with equal or unequal diameters. DN 40 - DN 1200



HIGH PRESSURE COUPLINGS

Provides a mechanical joint between similar or dissimilar pipes in high pressure environments. DN 150 - DN 2000



SOCKET JOINT LEAK CLAMPS

Provide a permanent and economical seal over a leaking socket-spigot joint. DN 80 - DN 1200

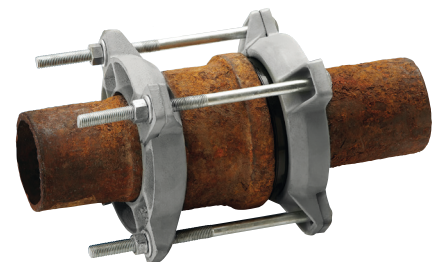

WANG COMPONENTS

CNR GIBSON STREET & SANDFORD ROAD, WANGARATTA, VICTORIA 3677
 PHONE 03 5722 7400 / FAX 03 5722 7444 - EMAIL sales@wang.com.au - WEB wang.com.au

All WANG trademarks and logos are owned by Wang Components, All other brand or product names are trademarks or registered marks of their respective owners. Because we are continuously improving our products and services, Wang Components reserves the right to change specifications without prior notice AP0315 © 2015 Wang Components. All Rights Reserved.

